

Chapter 1. A brief introduction to Western Blotting

Applying gel electrophoresis to separate proteins by molecular weight, western blotting has become an increasingly popular and powerful analytical technique in detecting and visualizing proteins. Membranes, mostly Nitrocellulose or PVDF (polyvinylidene fluoride), can be used to support solid-phase immunoassays, due to its capability of binding proteins. Proteins are transferred to a membrane, where they are probed and/or detected using antibodies specific to the target protein.

Three elements, simple but not easy, are considered to be of great significance when it comes to Western blotting procedures: the separation of protein mixtures by size during gel electrophoresis; the efficiency of transfer of separated proteins to the membranes; and last but not least, the detection of the protein of interest using specific antibodies.

A Western blotting experiment conducted successfully always ends up with a band visualized on a blotting membrane, X-ray film, or an imaging system.

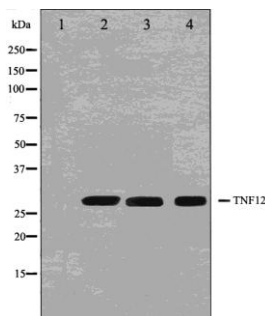

Western blotting analysis of extracts from HeLa cells (Lane 2), A549 cells (Lane 3) and Hepg2 cells (Lane 4) with TNF12 Antibody. The lane on the left is treated with the synthesized peptide.

The standard procedure for western blotting is as follows:

- (i) **Sample preparation:** Cells and tissues need to be lysed to release the target proteins so that they can migrate individually during transfer. Lysis buffers which differ in their ability to solubilize proteins are employed to serve that purpose.
- (ii) **Transfer:** Proteins are transferred from electrophoresis gel to a membrane while maintaining their exact protein patterns; to block non-specific binding of antibodies, 5% non-fat dry milk or BSA can be used to saturate unoccupied protein sites;

- (iii) **Detection:** A specific primary antibody is used to probe the protein of interest, and then a secondary antibody, which is specific for the primary antibody type and is conjugated to a detectable enzyme, is added for incubation. Converted into insoluble and detected products, enzyme substrates leave a visible colored trace at the site of the band representing the protein of interest.

Antibody selection:

The selection of appropriate antibody is of top priority regarding any successful Western blot. The highly specific interaction between an antibody and an antigen is one of the most important factors.

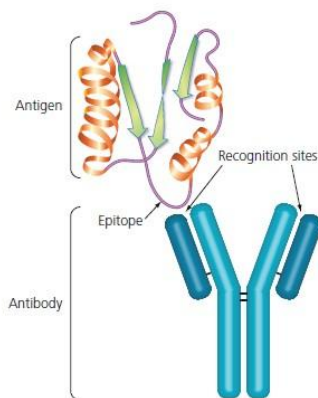

The antigen, usually a protein or peptide, is the target of the antibody. The precise point of interaction is between a small region of the antigen, aka an epitope, and the recognition sites found on the arms of the antibody molecule.

Most Western blots are carried out under denaturing and reducing conditions which remove all higher order protein structure. In contrast, some epitopes can be conformational, forming a 3D structural configuration of amino acids that will be lost upon denaturation of the protein. Thus, not all antibodies are applied to the Western blotting. Antibodies selected for Western blotting should be tested by the antibody supplier in the first place, with experimental conditions offered on the datasheet.

Monoclonals vs. Polyclonals

Both monoclonal and polyclonal antibodies are created when an antigen, usually a protein or peptide (coupled with KLH preferred), is injected into an animal, its immune system responds by producing antibodies specifically against that antigen, or various epitopes on that antigen to be exact. Polyclonal antibody is a mixture of immunoglobulin molecules that bind to several different epitopes found on a single antigen. Monoclonal antibody, by comparison, binds to a single epitope within a target antigen. Monoclonals are made by fusing antibody producing cells from the spleen of the immunized animal (commonly a rat or mouse) with an immortalized cell line to produce single specificity antibodies that



can be purified from tissue culture supernatant. Both monoclonals and polyclonals can be used in Western blotting.

Chapter 2. Sample preparation

Western blotting relies on a purified, semi-purified, or crude extract of cellular proteins containing a target protein that can be detected by antibodies. Several key steps are required to take the sample from the cell to a detectible band on a Western blot.

- 1) Sample production by lysis or homogenization to solubilize and release cellular proteins.
- 2) Separation of protein mixtures using gel electrophoresis.
- 3) Transfer of separated proteins to a blotting membrane which can be manipulated more easily

Cell Lysates

Cells are harvested, washed, and lysed to release the protein of interest. Crude cellular lysates can be prepared from immortalized cell lines known to express the target protein, or from transfected cells carrying a protein expression vector. Many different cell types, including mammalian, insect, yeast, or bacteria, can be used to supply the protein needed with slight variations in preparation. To minimize the effect of proteolysis, dephosphorylation and denaturation, all steps must be carried out in a cold room, or on ice.

For a quick check, it is suggested to lyse cells directly in gel loading buffer. However, sonication may be necessary to disrupt the highly viscous cellular DNA. Usually, 20-50 mg of cellular lysate is loaded per lane for gel electrophoresis.

The selection of the proper lysis buffer and its appropriate volume is subjected to the type of protein, which is being isolated as well as the particular cells used as a source. Lysis buffers vary from very gentle ones with no detergent to harsher solutions such as RIPA (Radio Immuno Precipitation Assay) buffer, which is denaturing and contains multiple detergents.

Typically, NP-40 (Nonidet P-40) lysis buffer, with a milder non-ionic detergent, is used for the isolation of soluble cytoplasmic proteins. Plus, RIPA buffer is chosen because it reduces background, and because sometimes multiple detergents are required to fully release membrane bound or nuclear proteins.

The amount of lysis buffer is determined based upon a cell count, or else it is estimated based upon the size of the tissue culture vessel. The accompanying table provides some suggested starting points.

Purified or Semi-purified Extracts

The simplest source of starting material for Western blotting is purified or semi-purified protein



samples that are produced in the course of protein purification. These samples rarely require any further manipulation and are simply mixed with gel electrophoresis loading buffer (Laemmli sample buffer). When using a purified or semi-purified protein preparation, it is possible to load a much smaller amount of total protein onto the gel. Usually 0.5-1 mg of purified or semi-purified protein is sufficient to observe a strong signal.

Determining Protein Concentration

To ensure that samples are in the proper range of detection for the assay, and so they can be compared on an equivalent basis, it is important to know the concentration of total protein in each sample. There are various methods available for determining protein concentration using house made or commercially supplied kits and reagents. The simplest method entails measuring the absorbance of the lysate solution at 280 nm or 205 nm. Alternatively, several protein assays are available which rely upon the reduction of metal ions by the peptide bond, e.g. the Lowry and BCA assays; or by dye binding, as with the Bradford assay. In all instances, a color change results that is proportional to the amount of protein in the sample. Protein concentration is determined by comparing the target samples to a known standard, such as BSA diluted in lysis buffer. In order to get the most accurate measure of protein concentration, it is highly recommended to test a few dilutions of the sample to ensure that the results lie in the linear range of the protein assay.

Chapter 3. Electrophoretic Transfer

The initial step in blotting is the transfer of proteins from a gel to a solid membrane support, during which protein patterns are precisely preserved. Immobilization of proteins on a membrane makes the proteins accessible to probes and thereby enables quantitative detection.

Generally, electrophoresis employs polyacrylamide gels and buffers loaded with sodium dodecyl sulfate (SDS). SDS-PAGE (SDS polyacrylamide gel electrophoresis) puts polypeptides into a denatured state. Once treated with strong reducing agents to remove all higher order protein structure and consequently separate the proteins by their size (molecular weight, usually measured in kilodaltons, kDa). Sampled proteins become covered in the negatively charged SDS and move to the positively charged electrode through the acrylamide mesh of the gel. Smaller proteins travel faster, so proteins are separated accordingly.

Molecular weight markers are pre-made mixtures of proteins whose molecular weights have been defined. They are a useful and powerful means of monitoring progress for gel running, transfer efficiency checking, and the blotting orienting. The standards, however, should not be overloaded as they may obscure signal from the protein of interest.

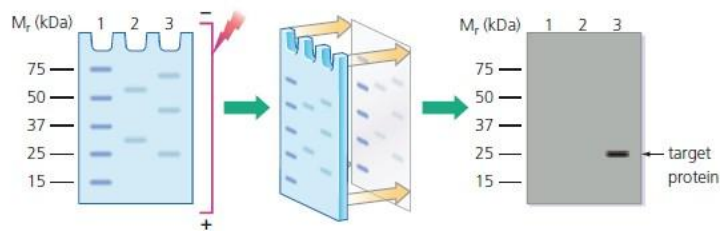

The uniformity and overall effectiveness of electrophoresis can be confirmed by staining the membrane with Ponceau S. Ponceau S is a reversible red stain applied in an acidic solution which can identify the presence of protein bands directly and swiftly. Also, though not typically used on a Western blot before detection, Coomassie brilliant blue stain is sometimes employed to stain the gel after transfer in order to identify what remains behind.

Blocking

The membrane is chosen for its ability to bind protein. Since antibodies also are proteins, interactions between the membrane and the antibody used for detection of target protein must be prevented in the first place. Blocking of non-specific binding can be achieved by placing the membrane in a dilute solution of protein - typically 5% Bovine serum albumin (BSA) or non-fat dried milk in Tris-Buffered Saline (TBS), also with a small amount of Tween 20 detergent being added. The protein in the dilute solution attaches to the membrane in all places where the target proteins have not attached. When the antibody is added, there is no room on the membrane for it to attach on the binding sites except that of the target protein. This reduces "noise" in the final product of the western blot, giving rise to clearer results and eliminating the odds of false positives.

Normally, BSA blocking solutions are preferred when it comes to anti-phosphoprotein antibodies. This is because milk solutions contain casein, which is itself a phosphoprotein, thus it will interfere with the assay results.

Incubation

After blocking, a dilute solution of primary antibody is incubated with the membrane under gentle agitation, usually lasts for a few hours at RT or overnight at 4° C. To ensure specific binding, a prolonged incubation yet no more than 18 hours is preferred.

Since antibody itself varies in its levels of purity and specific binding properties, it is reasonable to assume that there will be differences in concentration. Datasheet should provide recommended dilution for a particular application. However, it is highly suggested that a test of dilution ranges with each new antibody be arranged, optimizing experimental conditions for the samples.

After rinsing the membrane to remove excess primary antibody, the membrane is exposed to another antibody, directed at a species-specific portion of the primary antibody. This is known as a secondary

antibody, and due to its targeting properties, tends to be referred to as "anti-mouse," "anti-goat," etc. Secondary antibody is usually linked to a reporter enzyme such as AP (alkaline phosphatase) or HRP (horseradish peroxidase). This means that several secondary antibodies will bind to one primary antibody and thus the signal can be enhanced. Make sure to have a sufficient volume, and gentle agitation to keep the blot evenly exposed to the reagents without drying out during the whole process.

Chapter Detection

After the unbound probes are washed away, the western blot is ready for detection of the probes labeled and bound to the target protein. In practical terms, not all westerns reveal protein only at one band in a membrane. Size approximations are taken by comparing the stained bands to that of the marker or ladder loaded during gel transfer. The process is repeated for a structural protein, such as actin or tubulin, which do not change between samples. To ensure correction for the amount of total protein on the membrane, thereby avoiding errors or incomplete transfer, the amount of target protein is normalized to the structural protein to control between groups.

The colorimetric detection method depends on incubation of the western blot with a substrate that reacts with the reporter enzyme that is bound to the secondary antibody. This converts the soluble dye into an insoluble form of a different color that precipitates next to the enzyme to stains the membrane. Development of the blot is then stopped by washing away the soluble dye.

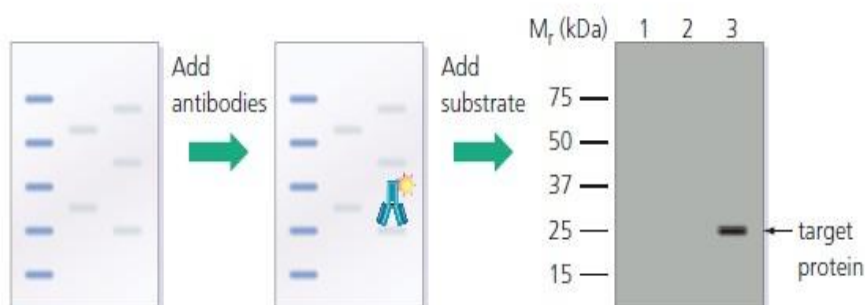

Chapter 5. Gels, blotting, buffers and protocols

Loading Buffer

Once the protein concentration has been determined, samples are diluted in gel loading buffer, also called 2x Laemmli sample buffer. This buffer contains glycerol so that the samples sink easily into the wells of the gel, and a tracking dye (bromophenol blue) which migrates through the gel first to indicate how far the separation has progressed. For Western blots, SDS (sodium dodecyl sulfate) and a reducing



agent are also present in the gel loading/sample buffer to fully denature the protein and remove all higher order structure. Samples are heated in gel loading/sample buffer for either 5 minutes at 100 ° C, or 10 minutes at 70 ° C to help denaturation. Consequently, samples can remain at RT if they are to be used immediately, or placed at 4 ° C or -20 ° C for later analysis.

Since the buffer is prone to lose its capacity to maintain a stable pH during transfer, it should never be used more than once, regardless of what kind is selected.

Controls and Standards

It is highly suggested to include a positive and a negative control on the gel along with the samples that are to be evaluated. The positive control is important for confirming the identity of the target since it will produce a reference band on the blot, showing the expected migration of the target protein and confirming the activity of the antibodies. Positive controls are also very helpful for troubleshooting, and for comparing the data between separate blots. If possible, it is also useful to include a negative sample control, such as known null cell line, as a means of confirming that the signal is specific to the protein of interest.

The final component required for the gel is a molecular weight standard since a key feature of Western blotting is to provide information on the size of the protein. Also known as molecular weight markers, these are premade mixtures of proteins with known molecular weights, usually 5-6 proteins spanning the range from 10 kDa to 200 kDa. Molecular weight standards come in a variety of formats, including unstained, prestained, multi-colored, or directly labeled for Western detection. They are an excellent means of monitoring progress while the gel is running, of checking transfer efficiency, and for orienting the immunoblot. The protein standards should not be overloaded since they may obscure signal from the target protein.

Gels

Separating the target protein properly from the mixture makes it possible to be clearly probed later with a specific antibody. The gel, more often than not, is made and run under denaturing conditions (25 mM Tris base, 192 mM glycine, 0.1% SDS, at pH 8.3). However, alternative gel conditions can be used, depending upon the protein under investigation and the aims of the experiment.

Options include: non-denaturing, non-reducing, native, two dimensional separations (by size and by isoelectric point), and buffer variations that are more suited to the separation of smaller or larger proteins. Make sure that the buffer used is compatible with later steps in the following procedure and the blotting materials. SDS-PAGE gels usually consist of a main gel, which is poured between two glass or plastic plates and topped by a short stacking gel. Gels can be made with a uniform acrylamide percentage, or with a continuously varying gradient that yields improved resolution over a broader range of molecular weights.

See the table below for some common gel percentages and their separation ranges.

Acrylamide Concentration (%)	Separation Range (kDa)
20	4~40
15	12~45
12.5	10~70
10	15~100
8	25~200

Apparatus

Electrotransfer from a gel to a membrane is done by directing an electric field across the thickness of the gel to drive proteins out of the gel and on to the membrane. There are two types of apparatus for electrotransfer: (i) buffer-filled tanks and (ii) “semi-dry” transfer devices.

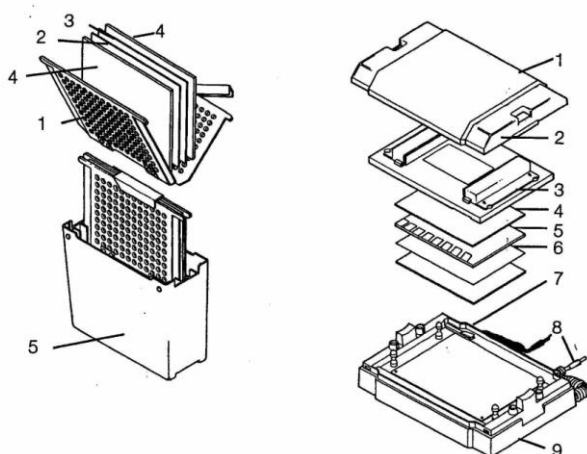

Transfer tanks are made of plastic with two electrodes mounted near opposing tank walls. A non-conductive cassette holds the membrane in close touch with the gel. The cassette assembly is placed vertically into the tank parallel to the electrodes and immersed in electrophoresis buffer. A large volume of buffer in the tank is preferred, due to the ability to dissipates the heat generated during transfer.

In semi-dry blotting, the gel and membrane are sandwiched horizontally between two stacks of buffer-wetted filter papers in direct contact with two closely spaced solid plate electrodes. The close spacing of the semidry apparatus provides for high field strengths. The term “semi-dry” refers to the limited amount of buffer confined to the stacks of filter paper.

Instead of semi-dry apparatus, tanks devices is more often employed most routine work. With tanks,



transfers are somewhat more efficient than with semi-dry devices. Under semi-dry electro-transfer conditions, some low-molecular-weight proteins are driven through the membranes and because low buffer capacity limits run times, and proteins of higher molecular weight can be poorly transferred.

Buffers & Membranes

Prepare transfer buffer appropriate to the electrotransfer apparatus. Refer to the recommendations of the manufacturer of the apparatus or use those given here. Make about 1 liter of buffer more than is required to fill the apparatus. Do not adjust the pH of transfer buffers; make sure that they are close to the expected pH.

Remove the gel from the cassette and soak it in transfer buffer for about 10 min. It is helpful to cut off the stacking gel, if one was used, since the soft gel will stick to the transfer membrane.

N.B. Azide should never be added to any buffers because it will compromise the activity of the HRP enzyme.

PBS

8.0 g NaCl
0.2 g KCl
1.15 g Na₂HPO₄
0.2 g KH₂PO₄

Dissolve in 800 ml distilled water, adjust pH to 7.4, and then add more dH₂O to a final volume of 1 liter. Sterilize by autoclaving and store at RT.

TBS

8.0 g NaCl
0.2 g KCl
3.0 g Tris base

Dissolve in 800 ml distilled water, adjust pH to 8.0 with 1 M HCl, and then add more dH₂O to a final volume of 1 liter. Sterilize by autoclaving and store at RT.

Electrophoresis and Transfer Buffers (Laemmli 2x Sample Buffer)

4% SDS
20% Glycerol
125 mM Tris, pH 6.8
0.02% Bromophenol blue
200 mM DTT or 10% bME (Keep fresh before use for best results)

Gel Electrophoresis Running Buffer

25 mM Tris base

190 mM Glycine

0.1% SDS

Transfer Buffer

50 mM Tris base

380 mM Glycine

0.1% SDS

20% Methanol

Ponceau S Stock Solution

2% Ponceau S

30% Trichloroacetic acid

30% Sulfosalicylic acid

Dilute 10-fold in distilled water prior to use.

Washing Buffers**PBST**

PBS with 0.1% Tween 20

TBST

TBS with 0.1% Tween 20

5% Non-fat Dry Milk in PBST or TBST

Add 5 g non-fat dry milk powder to 100 ml PBST or TBST.

Dissolve under gentle agitation. Store at 4 ° C.

5% BSA in PBST or TBST

Dissolve 5 g of BSA Fraction V in 100 ml PBST or TBST with gentle stirring. Store at 4 ° C.

The solid support onto which the separated proteins are transferred is usually of two types, nitrocellulose or polyvinylidene fluoride (PVDF) membrane, both of which bind proteins with high affinity. However, one major difference between nitrocellulose and PVDF membranes relates to the ability of each to support "stripping" antibodies off and reusing the membrane for subsequent antibody probes. Nitrocellulose is brittle and thus it is usually less effective when blots need to be reused, while PVDF membranes are also thicker and more resistant to damage during use. Besides, PVDF must be soaked in 95% ethanol, isopropanol or methanol for activation before use. Sometimes higher background staining is seen with PVDF membranes,

Immuno-detection



Appropriate primary antibodies can be produced in any convenient animals, such as rabbits or mice. Antibodies to many important proteins can be purchased from a number of commercial vendors. Secondary antibodies (e.g., goat anti-rabbit immunoglobulin) conjugated to enzymes are also commercially available. The most common enzymes used in western blotting are alkaline phosphatase and horseradish peroxidase. The preferred substrate for alkaline phosphatase is the mixture of 5-bromo-4-chloro-3-indolyl phosphate (BCIP) and nitroblue tetrazolium (NBT). The substrate BCIP is dephosphorylated by the enzyme and then oxidized in a reaction coupled to reduction of NBT. The resultant highly visible purple product is deposited on the protein bands or spots. With horseradish peroxidase, use 4-(chloro-1-naphthol) or diaminobenzidine as substrate (with added hydrogen peroxide). Chemiluminescent substrates for horseradish peroxidase are based on oxidation of luminol. The luminol substrate provides the most sensitive signal of the blotting substrates but requires photographic exposures or specially configured imaging devices.

Protocol:

1. Follow instructions to set up the transfer apparatus. Cut filter paper and membrane to a appropriate size with a clean, sharp scalpel. Soak filter paper and sponge pads (if used) in transfer buffer. (Do not touch the membrane with bare hands. Use gloves and blunt, flat-blade forceps to manipulate the membrane.)
2. Completely wet the transfer membrane with transfer buffer. (PVDF must be wetted in methanol before being placed in aqueous solutions.) Avoid air bubbles in the membrane by slowly sliding it into buffer (or methanol) at a slight angle or by floating it on buffer. Immerse the membrane in buffer and soak it for 15 min. Do not let the membrane run dry before beginning the transfer.
3. Place about 1 liter of transfer buffer in a large tray and assemble the transfer array in it. Use the buffer in the tray to keep all elements of the transfer array well wetted during assembling.
4. To avoid trapping air bubbles between the gel and the membrane, lay the membrane on the gel from the center to the ends, then gently roll a test tube or pipette on top of the membrane to push out air bubbles.
5. Put the transfer array into the transfer apparatus. Follow the manufacturer's instructions for electro-transfer.
6. Wash the membrane for 5~10 min in TBS.
7. Incubate the membrane for 30 min to 1 hr at RT in TBS containing 5% (w/v) non-fat dry milk to block excess protein binding sites on the membrane.



-
8. Wash the membrane twice, for 5 min each time, with TBST.

Blocking

9. Block membrane by incubating 1 hour at room temperature or overnight at 4°C with shaking in Blocking Solution (5% BSA, 0.05% Tween-20 in TBS (50mM Tris, 100mM NaCl, pH 7.6)).

Incubation with primary antibody

10. Dilute primary antibody at the appropriate dilution in Blocking Solution. Incubate the membrane with diluted primary antibody for 1 hour at 37°C, or 2 hours at RT, or overnight at 4°C with agitation.
11. Remove antibody solution. Wash the membrane 3 times for 5-10 minutes each time at room temperature in TBST (50mM Tris, 100mM NaCl, 0.05% Tween-20, pH 7.6) with shaking.

Note: Increase the concentration of Tween-20 to 0.1% reduces the background and increases the specificity, but it will reduce the sensitivity.

Incubation with Secondary Antibody

12. Incubate membrane with secondary AP conjugate diluted (according to manufacturer's instructions) in Blocking Solution for 1 hour at room temperature with shaking
13. Repeat Step 11.
14. Wash membrane with TBS for 2-5 minutes before proceeding Chemiluminescent Reaction.
15. Prepare and use the Chemiluminescent substrate according to the manufacturer's instructions.
16. Immediately wrap the membrane and expose to X-ray films for 10 second to 1 hour period. The exposure time may vary according to the amount of antibody and antigen.

Chapter 6. Trouble shooting

1. No signal

A blank blot film is the hardest to troubleshoot for western blots, because so many steps could

have gone wrong. The aim of this troubleshooting protocol is to get bands on the western blots as soon as possible.

Do the following steps in order. The total time needed is about 3 hrs and 30 mins.

Step 1. Secondary antibody, ECL reagents and film. - Time needed: 30min of western blot troubleshooting

- Pipet 1ul of secondary antibody directly onto a piece of membrane (nitrocellulose or PVDF)
- Pipet 1ul of a secondary antibody that works as a positive control onto the same membrane
- Draw a circle around the two spots with a pen and label them
- Soak the membrane in TBST for 10 min
- Develop the dot blot with your ECL reagent and film.

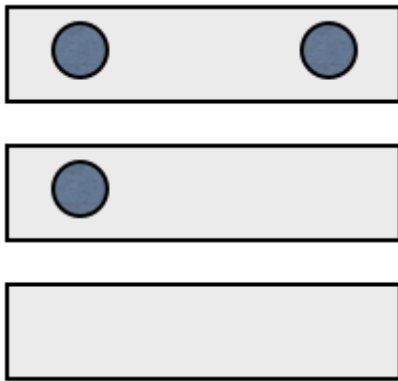

Results:

2 dots on the film- the problem is not your secondary antibody, ECL reagents or film - move to Step 2

Positive Control: Dot only on the film –secondary antibody has gone bad.

No dots on the film –ECL solution has gone bad.

Step 2. Primary and Secondary Antibody compatibility Time needed: 1.5 hr or so

- Pipet 1ul of your primary antibody directly onto a piece of membrane (nitrocellulose or PVDF)
- Pipet 1ul of a secondary antibody that works as a positive control onto the same membrane
- Draw a circle around the two spots with a pen and label them
- Block the membrane in blocking buffer for 30 min at RT
- Add the Secondary Antibody in blocking buffer to the membrane for 30 min at RT
- Wash the membrane X 3 changes in TBST
- Develop the dot blot with your ECL reagent and film/machine of choice.

Results



1. 2 dots on the film – Primary antibody and secondary antibody are compatible – skip ahead to Step 4
2. Positive Control Dot only on the film – There is a problem with your buffer or your secondary antibody is incompatible.
3. No dots on the film – This result is impossible if you have performed Step 1.

Step 2.5. Primary and Secondary Antibody compatibility part 2 – Time needed: 3 mins

- A. Check anyway to make sure your secondary antibody was raised against the correct species from the one your primary was raised (e.g primary is raised in rabbit, use anti-rabbit secondary). Goat – Anti-Goat, Mouse Monoclonal – Anti-Mouse, Rat Monoclonal – Anti-Rat, etc.
- B. Check to make sure your secondary is conjugated to HRP.

Move to Step 3.

Step 3. Western blot blocking buffer – 5% milk or 5% BSA - Time needed 1.5 hrs

In some cases, cross-reaction may occur between blocking agent and primary or secondary antibody. This protocol aims to test if the blocking buffers works effectively.

- A. Prepare the following three Blocking Buffers **FRESH**, check pH 100ml 5% Milk Blocking Buffer

100ml 5% BSA Blocking Buffer

100ml TBST

- B. Pipet 1ul of your primary antibody directly onto a piece of membrane (nitrocellulose or PVDF)
- C. Pipet 1ul of a secondary antibody that works as a positive control onto the same membrane
- D. Draw a circle around the two spots with a pen and label them
- E. Repeat steps B-D for a total of 3 separate blots
- F. Soak the trial blots in blocking buffers 1, 2, or 3 in separate containers for 30 min at RT. Make sure the containers are clean.
- G. Add the Secondary Antibody in blocking buffer to the membranes for 30 min at RT
- H. Wash the membranes X 3 changes in TTBS



I. Develop the dotblot with your ECL reagent and film/machine of choice.

Results (getting more complicated to interpret so stay with us)

100ml 5% Milk Blocking Buffer Blot

2 dots on the film – 5% Non-fat dry milk should be chosen for blocking buffer

Positive Control Dot only on the film – Don't use milk for blocking buffer or buy some new powdered milk

100ml 5% BSA Blocking Buffer Blot

2 dots on the film – 5% BSA should be chosen for blocking buffer

Positive Control Dot only on the film – Don't use BSA for blocking buffer or buy some new BSA

100ml TBST only Blot

2 dots on the film – Tween (TBST) is the choice for blocking buffer

Troubleshooting summary to this point:

At this point in just 3 hrs and 33 minutes, you have eliminated the following causes of blank film
Cross-reaction between blocking agent and primary or secondary antibody.

Bad Secondary antibody

Bad Primary antibody

Bad film

Bad ECL Reagents

Bad Membranes

Bad Buffers

Found the correct Blocking Buffer

Step 4 – The end of blank film

In this final step, we recommend you prove to yourself that everything is working correctly by testing the process on Western blot markers.

A. Load 1-2 ul of Western blot markers onto a SDS-PAGE gel and run the gel until the dye reaches the bottom

B. Transfer the markers to your membrane of choice

C. Block the membrane in blocking buffer of your choice for 30 min at room temperature (RT)

E. Add your Secondary Antibody in blocking buffer to the membrane for 30 min at RT

F. Wash the membrane X 3 changes in TTBS

G. Develop the Western blot with your ECL reagent and film/machine of choice.

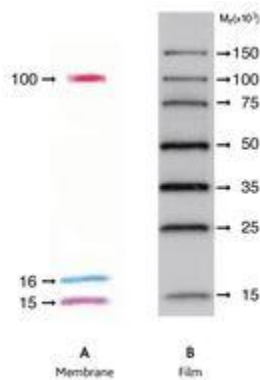

Hopefully you see markers on your film

Results

Markers show up on the film – everything is working correctly. Move on to primary antibody troubleshooting protocol (coming soon).

Nothing on the film – There is a problem with the markers, they have gone bad or are not what you think they are.

Wrong concentration of antibody or low affinity to the protein of interest;

Increase incubation duration and antibody concentration than initially, optimize conditions on dot blots

Inappropriate secondary antibody

Double check compatibility between primary and secondary antibodies; and repeat procedure with the correct combination

Antibody not applied for western blotting

Check datasheet for applications, and try alternative antibody suitable for western blotting

Activity lost due to improper and/or long time storage

Try antibody at different concentrations, and use fresh aliquots properly stored

Antigen not expressed to the target protein

Use another source of protein of interest

Insufficient loading of antigens in the gel

Check concentration of sample and increase loading amount

Poor transfer

Staining the membrane with Ponceau S and/or the gel with Coomassie brilliant blue;

Optimize transfer conditions, repeat using two membranes to avoid that the protein has transferred through the first one;



Pre-soak the membrane in MeOH then in transfer buffer if using PVDF membrane

HRP is compromised by Sodium azide contained in buffers

Use azide free buffers

Contaminated ECL detection reagents

Use fresh detection reagents

2. Faint bands and weak signal

Low concentration of primary and/or secondary antibody

Repeat experiment using higher concentration of antibodies, optimize concentration with dot blots

Low antigen-antibody binding affinity

Minimize the number of wash steps if need be, increase the antibody concentration than recommended

Not enough sample loaded in the gel

Check sample concentration, increase the amount of loaded sample

Non-fat milk may block some antigens

Decrease percentage of milk in the blocking and antibody solutions, try other blocking solution

Low efficiency of transfer

Confirm transfer efficiency with Ponceau S staining, optimize transfer conditions according to the size of target protein

Exposure time was too short

Prolong exposure time

3. Bands site lower than expected

Cleaved or degraded protein of interest

Use fresh sample which has been kept on ice, add fresh protease inhibitors to the lysis buffer

Same or similar epitope of another antibody has been detected

Try alternative antibody

4. Multiple bands of various molecular weights

Concentration of primary and/or secondary antibody may be too high

Optimize/ decrease primary and/or secondary antibody concentration



Cross-reactivity with similar epitopes of other proteins

Try an affinity-purified primary and/or secondary antibody

Different isoforms of protein

Check antibody specificity using blocking peptide

5. Smile shaped, not flat bands

Gel become overheated due to improper transfer conditions

Optimize gel transfer conditions, run gel at 4 ° C

Too much protein has been loaded

Try to load less sample and repeat with dilution series of sample;

Antibody concentration is too high

Reduce the concentration of antibody

6. Higher molecular weight than expected band(s)

Protein may be glycosylated, methylated or otherwise modified

Use enzymes to remove suspected modification to get molecular weight closer to expected

Dimers, multimers may be formed

Add fresh DTT or beta ME to samples and reheat before repeating experiment, prepare new samples with fresh loading buffer

7. Blurry bands

Too high a voltage when running a gel

Repeat transfer at lower voltage;

Incorrect running buffer composition

Prepare fresh new running buffer;

Trapped air bubble present during transfer

Remove air bubbles carefully between the gel and the membrane before transfer

8. Uneven Spots on the Blot

Antibodies bound to the blocking agent

Filter the blocking agent or try alternative one



HRP-linked secondary antibody has aggregated

Spin and filter secondary antibody to remove aggregates

Insufficient solution used during incubation and washing

Make sure the membrane is fully immersed and under agitation during the whole process

Trapped air bubbles

Remove air bubbles between the gel and the membrane prior to transferring

Uneven agitation during incubation

A shaker is preferred for incubation